

USER GUIDE

VERIZON ONETALK T67LTE 4G DESK PHONE



O P T U S

PACKAGE CONTENTS

The following items are included in your package.

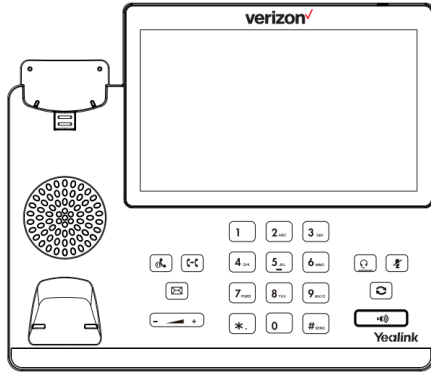

Phone

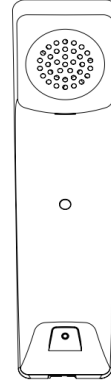

Handset

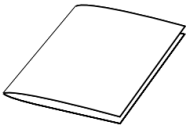

Quick-Start Guide

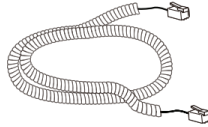

Handset Cord

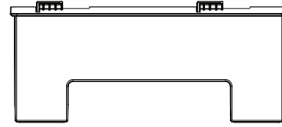

Stand



Power Adapter

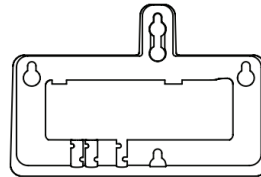

Wall-Mount Bracket
(Optional Accessory
SKU: T67WMB)

ASSEMBLING THE PHONE

DESK-MOUNT METHOD

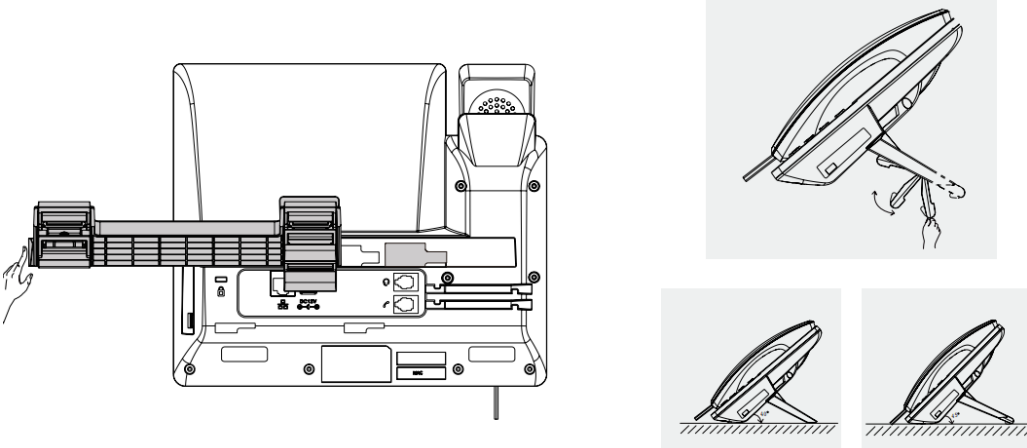

WALL-MOUNT METHOD

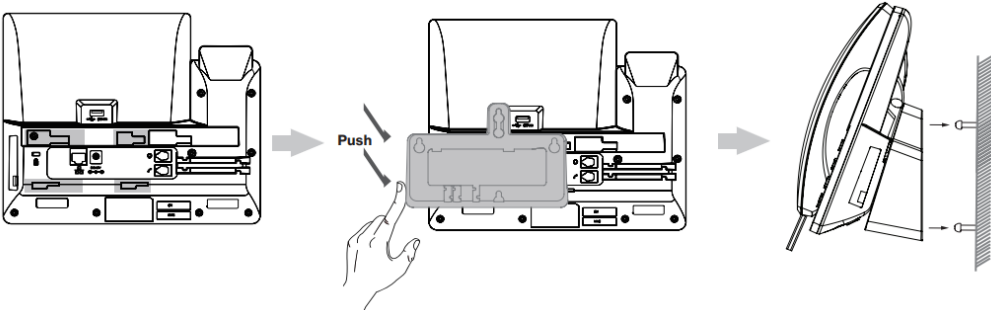

ASSEMBLING THE PHONE (CONTINUED)

CONNECT CABLES

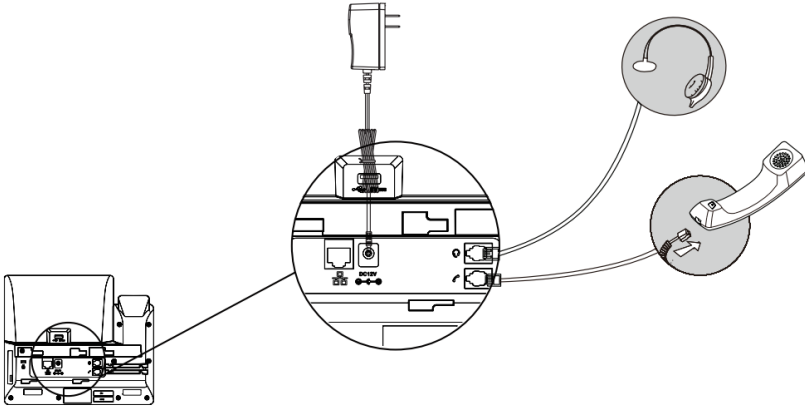

NOTE: The T67LTE Desk Phone should be used with a Yealink® original power adaptor (12 V/1 A) only. The use of a third-party power adaptor may cause the damage to the phone.

CONNECT ANY USB DEVICES (OPTIONAL)

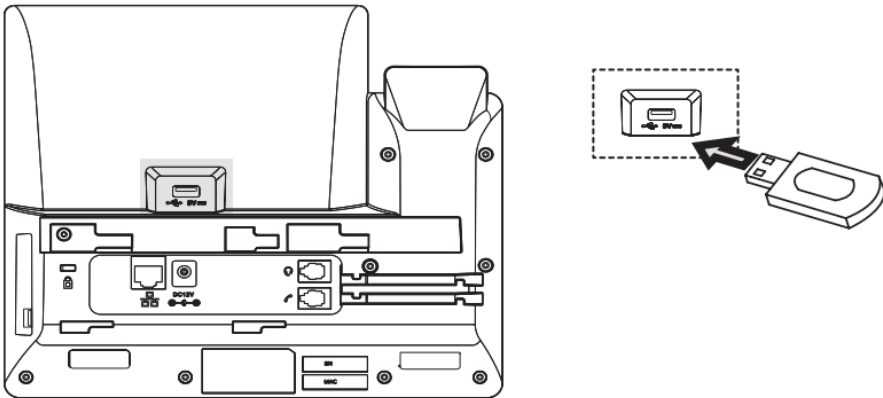

NOTE: The USB port can also be used to connect other USB devices, such as the EXP50.

GETTING TO KNOW YOUR DEVICE

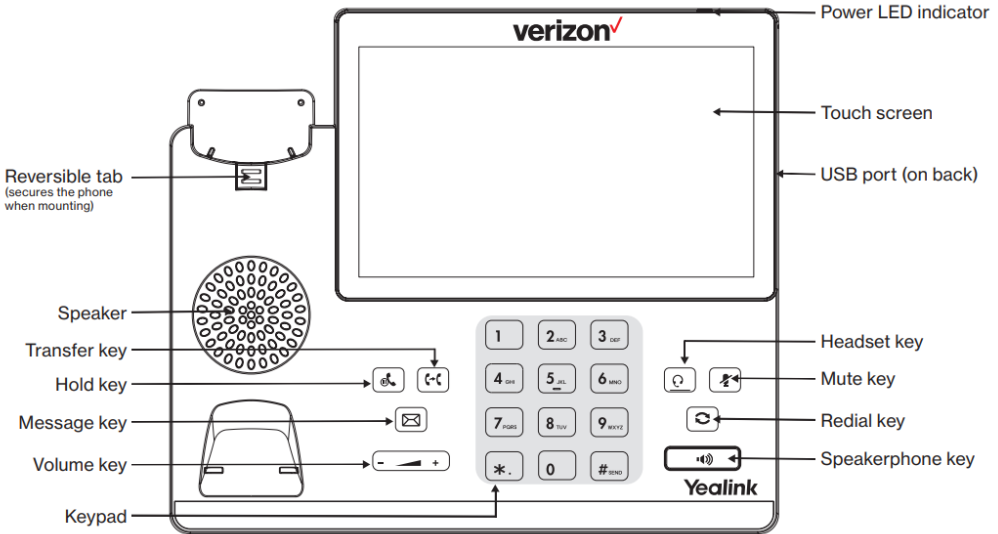

STARTING THE PHONE

Once the phone is powered on, it will automatically begin the initialization process and connect to the 4G network. The phone will go through a series of screens and update the firmware on the device; the first-time setup process takes about 15 minutes and should not be interrupted. You will know the phone is ready for use when the 911 address appears on the screen of the device. If that address is missing or is inaccurate, please contact your administrator immediately. It is critical that the address be accurate, because this is the location that will be given to emergency personnel when you dial 911.

USING THE TOUCH SCREEN



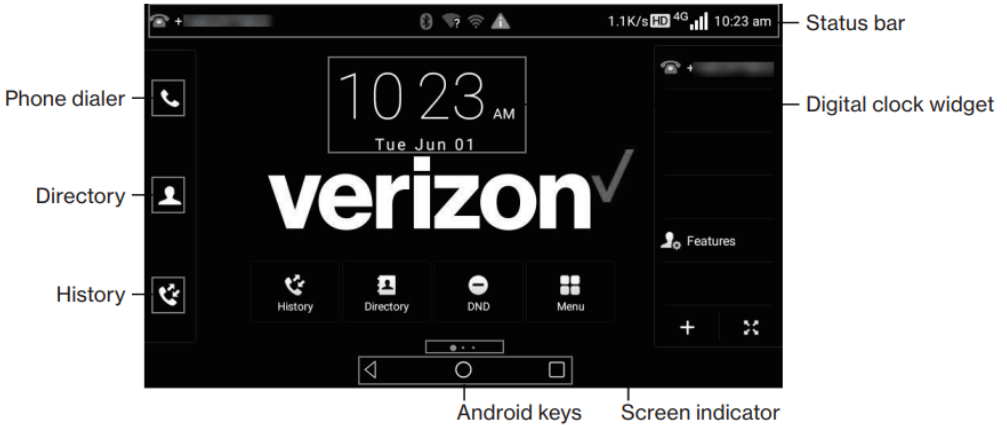



By default, the LTE Desk Phone supports three idle screens. The home screen displays as below:



TO NAVIGATE THE TOUCH SCREEN:

- Swipe left or right to switch among different idle screens.
- Tap ◀ to go back to the previous screen.
- Tap ○ to return to the idle screen.
- Tap □ to view and manage recently used applications.

STATUS ICONS

-  **MUTE MODE:** Mute mode is enabled.
-  **4G LTE ACTIVE:** The device is connected to a 4G LTE wireless network.
-  **SIGNAL STRENGTH:** Cellular network signal strength.
-  **NETWORK NOT AVAILABLE:** No wireless network is available.
-  (White) **WI-FI ACTIVE:** Wi-Fi is active.
-  (Green) **WI-FI AVAILABLE:** A Wi-Fi network is available.

CONTROL CENTER AND NOTIFICATION CENTER

Swipe down from the top of the screen to enter the control center and the notification center.

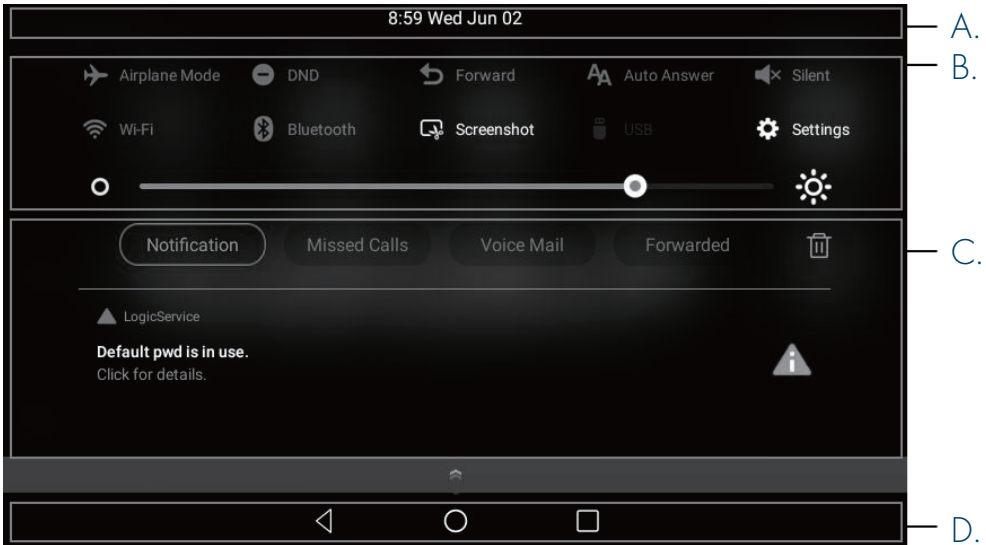

CONTROL CENTER AND NOTIFICATION CENTER (CONTINUED)

- A. Displays the phone's time and date.
- B. Control Center
- C. Notification Center
- D. Android Keys

CONTROL CENTER





- To turn on/off common functions quickly, capture a screenshot or go to the Settings screen, tap corresponding icons.
- To adjust the screen brightness, drag the slider.

NOTIFICATION CENTER

The notification center displays the list of Notifications, Missed Calls, Voice Mail and Forwarded.

- To delete all notifications, tap 
- To delete a specific notification, swipe left or right.
- To view the details, tap the desired notification message.

NOTIFICATION ICONS

-  **MISSED CALL:** A call has been missed.
-  **NEW EMAIL:** New email has arrived.
-  **NEW SMS HAS ARRIVED.**
-  **NEW VOICEMAIL:** New voicemail message has been received.

PLACING A CALL

USING A HANDSET:

1. Pick up the handset.
2. Enter the number, and then tap **SEND**.

USING THE SPEAKERPHONE:

1. With the handset on-hook, press 
2. Enter the number, and then tap **SEND**.

USING THE HEADSET:

1. With the headset connected, press  to activate the headset mode.
2. Enter the number, and then tap **SEND**.

NOTE: During a call, you can alternate between the headset, hands-free speakerphone and handset modes by pressing the **HEADSET** key or the **SPEAKERPHONE** key or by picking up the handset. Headset mode requires a connected headset.

ANSWERING A CALL

USING A HANDSET:

- Pick up the handset.

USING THE SPEAKERPHONE:

- Press 

USING THE HEADSET:

- Press 

NOTE: You can reject an incoming call by tapping **REJECT**.

ENDING A CALL

USING THE HANDSET:

- Hang up the handset or tap **END CALL**.

USING THE SPEAKERPHONE:

- Press  or **END CALL**.



USING THE HEADSET:

- Tap **END CALL**.

REDIALING A CALL

- Press  to enter the **PLACED CALLS** list, and then tap the desired entry.
- Press  twice when the phone is idle to dial out the last-dialed number.

MUTING AND UNMUTING A CALL

- Press  to mute the microphone during a call.
- Press  again to unmute the call.

HOLDING AND RESUMING A CALL

TO HOLD A CALL:

- Press  or **HOLD** during an active call.

TO RESUME THE CALL, DO ONE OF THE FOLLOWING:

- If there is only one call on hold, press  or tap the **RESUME** soft key.
- If there is more than one call on hold, tap the call you want to resume, and press  or tap the **RESUME** soft key.

TRANSFERRING A CALL

You can transfer a call in the following ways:

DIRECT TRANSFER

1. Tap the **TRANSFER** soft key during an active call. The call is placed on hold.
2. Enter the number you want to transfer to.
3. Press the **TRANSFER** soft key and select **DIRECT**.

CONSULTATIVE TRANSFER

1. Tap the **TRANSFER** soft key during an active call. The call is placed on hold.
2. Enter the number you want to transfer to, and then press  **#END**.
3. Tap the **TRANSFER** soft key when the second party answers.

FORWARDING A CALL

TO ENABLE CALL FORWARD

1. Tap **SETTINGS > FEATURES > CALL FORWARD**
2. Select the desired forward type:
 - **ALWAYS FORWARD:** Incoming calls are forwarded unconditionally.
 - **BUSY FORWARD:** Incoming calls are forwarded when the phone is busy.
 - **NO ANSWER FORWARD:** Incoming calls are forwarded if not answered after a period of time.
3. Enter the number you want to forward to. For **NO ANSWER FORWARD**, select the desired ring time to wait before forwarding from the **AFTER RING TIME** field.
4. Tap  to accept the change.

FORWARDING A CALL (CONTINUED)

INITIATING A CONFERENCE CALL

1. Tap **CONFERENCE** during an active call. The call is placed on hold.
2. Enter the number of the second party, and then tap **CONFERENCE**.
3. Tap **CONFERENCE** again when the second party answers. Three parties are now joined in the conference.

CONFIGURING AND USING SPEED DIAL

To configure a speed-dial key:

1. Tap **SETTINGS > FEATURES > DSSKEY**
2. Select the desired dsskey.
3. Select **SPEEDDIAL** from the **TYPE** field, select the desired line from the **ACCOUNT ID** field, enter a label in the **LABEL** field and then enter the number in the **VALUE** field.
4. Tap  to accept the change.

To use the speed-dial key:

- Tap the speed-dial key to dial out the preset number.

LISTENING TO VOICEMAIL MESSAGES (IF APPLICABLE)



The “message waiting” indicator on the idle screen indicates that one or more voicemail messages are waiting at the message center. The power LED indicator slowly flashes red.

To listen to voicemail:

1. Press  or **CONNECT**.
2. Follow the voice prompts to listen to your voicemail messages.



CUSTOMIZING YOUR PHONE

MANAGING CALL HISTORY



1. Tap 
2. Drag up and down to scroll.
3. Tap  after the desired entry, and then you can do the following:
 - Tap **SEND** to call the entry.
 - Tap **ADD** to add the entry to the local directory.
 - Tap **EDIT** to edit the entry before calling.
 - Tap **BLOCKLIST** to add the entry to the block list.
 - Tap **DELETE** to delete the entry from the list.

MANAGING THE CONTACT DIRECTORY



Adding a contact:

1. Tap 
2. Tap  to add a contact.
3. Enter a unique contact **NAME** in the Name field and contact numbers in the corresponding fields.
4. Tap  to accept the change.

Editing a contact:

1. Tap 
2. Tap  after the desired entry.
3. Edit the contact information.
4. Tap  to accept the change.

Deleting a contact:

1. Tap 
2. Tap  after the desired entry and then tap **DELETE**.
3. Tap **OK** when the LCD screen prompts, "Delete selected item?"

ADJUSTING THE VOLUME

Press  to adjust the volume.

SETTING RINGTONES

1. Tap **SETTINGS > BASIC SETTINGS > SOUND > RING TONES**
2. Select Common or the desired account.
3. Select the desired ringtone.
4. Tap  to accept the change.

REGULATORY NOTICES

Operating ambient temperatures:

- Operating temperature: +14° F to 113° F (-10° C to 45° C)
- Relative humidity: 5% to 90%, noncondensing
- Storage temperature: -22° F to +160° F (-30° C to +70° C)

SAFETY INSTRUCTIONS

Save these instructions. Read these safety instructions before use!

The following basic safety precautions should always be followed to reduce the risk of fire, electrical shock and other personal injury.

GENERAL REQUIREMENTS

- Before you install and use the device, read the safety instructions carefully.
- During the process of storage, transportation and operation, please always keep the device dry and clean.
- During the process of storage, transportation and operation, please avoid smashing or dropping the device.
- Do not attempt to dismantle the device.

ENVIRONMENTAL REQUIREMENTS

- Place the device in a well-ventilated place. Do not expose the device to direct sunlight.
- Keep the device dry and free of dust.
- Place the device on a stable and level surface.
- Please do not place heavy objects on the device.
- Do not place the device on or near any flammable or fire-vulnerable materials, such as rubber.
- Keep the device away from any heat source or open flame, such as a candle or an electric heater.
- Keep the device away from any household appliance with a strong magnetic field or electromagnetic field, such as a microwave oven or a refrigerator.

OPERATING REQUIREMENTS

- Do not let a child operate the device without supervision.
- Do not let a child play with the device or any accessory in case of accidental swallowing.
- Please use only the accessories provided or authorized by the manufacturer.
- The power supply of the device should meet the requirements of the input voltage of the device.
- Before plugging in or unplugging any cable, make sure that your hands are completely dry.
- Do not spill liquid of any kind on the product or use the equipment near water, for example, near a bathtub, washbowl, kitchen sink, wet basement or swimming pool.
- Do not tread on, pull or overbend any cable in case of malfunction of the device.
- During a thunderstorm, stop using the device and disconnect it from the power supply.
- If the device emits smoke or an abnormal noise or smell, disconnect the device from the power supply and unplug the power plug immediately. Contact the specified maintenance center for repair.
- Do not insert any object into equipment slots that is not part of the product or auxiliary product.
- Before connecting a cable, connect the grounding cable of the device. Do not disconnect the grounding cable until you disconnect all other cables.

CLEANING REQUIREMENTS

- Before cleaning the device, stop using it and disconnect it from the power supply.
- Use a piece of soft, dry antistatic cloth to clean the device.
- Keep the power plug clean and dry. Using a dirty or wet power plug may lead to electric shock or other hazards.

FCC STATEMENT

This device complies with Part 15 of the FCC Rules. Operation is subject to the following two conditions: 1) This device may not cause harmful interference, and 2) this device must accept any interference received, including interference that may cause undesired operation.

ENVIRONMENTAL RECYCLING

This device needs to be treated as an electronic device for recycling purposes.

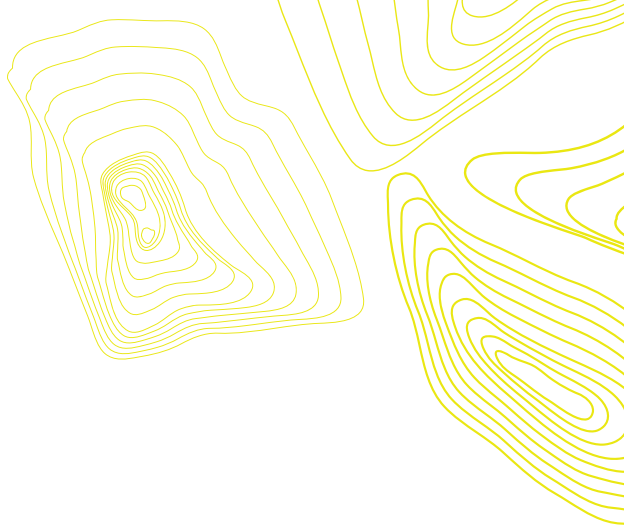

OPTUS

833.487.0003 EXT. 711 | [OPTUSINC.COM](https://www.optusinc.com)

